

NHRC-2 Repeater Controller User Guide

Rev D PCB only

Contents

1. Installation

- 1. Electrical Connections**
- 2. Adjusting the Audio Levels**
- 3. Initializing the Controller**

2. Programming

- 1. Controller Modes**
- 2. Programming the Controller**
 - 1. Programming the Timers**
 - 2. Programming the CW Messages**
 - 3. Programming the Flag Bits**
 - 4. Recording the Voice Messages**
- 3. Enabling/Disabling the Repeater**

3. Operating

- 1. About the IDs**
- 2. The Tail Message**
- 3. Using the Tail Message as the Courtesy Tone**

Index of Tables

- Configuration Flag Bits

NHRC-2 User Guide

Electrical Connections

Pin	Use
1	Ground
2	+13.8 Volts
3	PTT (active low)
4	TX Audio
5	RX Audio
6	CAS +
7	CAS -
8	Ground/TX Audio Return
9	Ground/RX Audio Return

Receiver audio can typically be taken from the high side of the squelch control. This audio must be de-emphasized with the controller's optional de-emphasis circuit, which provides a -6dB/octave slope. Optionally, audio can be taken from later in the receiver's audio chain, where it is already de-emphasized. Care must be taken that this source of audio is not subject to adjustment by the radio's volume control. If the receiver audio has not been properly de-emphasized, either in the receiver itself or on the controller board, the repeater will have a very "tinny", unnatural sound to it.

To de-emphasize the receiver audio on the controller board, install a 0.0068uF capacitor in position C3, change R3 to 51K, and change R4 to 510K. These values should be considered a good starting point. You may want to experiment with the values of C3 and R4 to get better sounding audio. We have had consistently good results with this de-emphasis network.

The receiver must provide a signal present indication (also called COR, RUS, CAS) to the controller. Because of the varieties of polarity and state that this signal can take, we have chosen to implement the controller's signal present input with an opto-isolator (ISO1). The anode and cathode of the LED in the opto-isolator are exposed through a current limiting resistor (R30). This allows easy interfacing to active-high, active-low, and combinations of both to indicate the presence of a received signal to the controller. Clever wiring can allow the user to create CTCSS and COR, CTCSS or COR, etc. configurations. Note that **both** the

CAS+ and CAS- terminals must be connected to something in order for the controller to detect the signal present indication.

Transmitter audio can be fed directly into the microphone input of the transmitter. VR2 (marked TX LVL) is the master level control, used to set the audio level into the transmitter. The transmitter's deviation limiter (sometimes called IDC) should be set such that the transmitter cannot overdeviate, regardless of input signal level. One way to adjust transmitter deviation is to set the transmitter deviation limiter wide open (unlimited), adjust the controller's master output until the transmitter is slightly overdeviating, then set the transmitter's deviation limiter to limit just below 5 KHz deviation. Then reduce the controller's master output until the transmitted audio does not sound compressed or clipped. Transmitter deviation should be adjusted with a service monitor or deviation meter.

Transmitter keying is provided by a power MOSFET (Q6) configured in an open-drain circuit. This can be used to key many transmitters directly. The MOSFET essentially provides a closure to ground for PTT. For other transmitters, the MOSFET can drive a small relay to key the radio. Although this MOSFET can handle several amps, we recommend that no more than 250mA of current be drawn through it, because the trace on the PC board is somewhat narrow.

2. Adjusting the Audio Levels

Preset all potentiometers to midrange. Connect an oscilloscope probe or DVM to pin 15 of U3 (the M8870 DTMF decoder). (Use the power supply ground for the scope's ground or the DVM's return.) Key a radio on the input frequency, send some touch-tones, and adjust VR1 (marked RX LVL) until DTMF decoding is reliably indicated by a 5-volt level on U3 pin 15. Disconnect the oscilloscope or DVM. Adjust VR2 (marked TX LVL) to adjust transmitter deviation, ideally measured with a deviation meter or service monitor. Adjust VR6 (the beep level) to set the courtesy tone and CW tone level.

The easiest way to adjust the ISD1420 input and output level is to select the simplex repeater mode and record messages until the audio sounds right. VR3 (marked RECORD LVL) adjusts the record audio level into the ISD1420. Adjust this control for the best sounding record audio. VR5 (marked SPEECH LVL) sets the ISD1420 playback level. Adjust this control for best acceptable transmitter deviation. VR4 (marked PROC RX LVL) is used to set the receiver audio level, and may not need to be adjusted from midpoint.

3. Initializing the Controller

To initially program your secret code into the controller, you must apply power to the controller with the pins on the INIT jumper, (SW1) shorted, putting the controller into the initialize mode. Remove the jumper a few seconds after power is applied. All of the values stored in the EEPROM will be reset to defaults, and

the controller will be ready to accept the 4-digit secret access code. This will reset the CW ID to the default value "DE NHRC/2" as well. When the controller is in the initialize mode the courtesy tone is 1/2 second long, instead of the usual 1/5 second. Key up and enter your 4-digit access code. The controller should respond with the normal (1/5 second) courtesy beep. The secret access code is stored in non-volatile memory in the PIC16F84 microcontroller. You will use this code as the prefix for all commands you send to the controller.

2. Programming

1. Controller Modes

The controller can operate in 3 different modes:

- Repeater Controller Mode
The controller operates a full-duplex repeater, with a courtesy tone and stored voice messages.
- Link Controller Mode
This is a variation of Repeater Controller Mode where the ISD1420 voice storage chip can be deleted to lower the cost of the controller. This mode is intended to control remote receivers that are essentially crossband repeaters. Normally, when using link controller mode, the hang time is set to 0 seconds, and the controller is programmed to suppress DTMF muting, so the user's DTMF commands will appear on the input of a "downstream" controller. The controller adds remote control, a timeout timer and CW ID capability to remote or link receivers.
- Simplex Repeater Controller Mode
This mode allows simplex (as opposed to duplex) radios to be used as repeaters. Up to 20 seconds of received audio is stored in the ISD1420 voice storage chip, and is "parroted" back when the user unkeys. The ID message is played in CW.

2. Programming the Controller

All programming is done by entering 8-digit DTMF sequences. The first 4 digits are the *passcode* chosen at initialization. The next 2 digits are an *address* or a *function code*. The last 2 digits are the *data* for address or function. To enter programming information, you must key your radio, enter the 8 digits, then unkey. If the controller understands your sequence, it will respond with "OK" in CW. If there is an error in your sequence, but the passcode is good, the controller will respond with "NG". If the controller does not understand your command at all, it will not respond with anything other than a courtesy beep, and then only if the courtesy beep is enabled.

Responses to Commands

Response	Meaning
"OK"	Command Accepted
"NG"	Command address or data is bad
courtesy beep or nothing	Command/password not accepted

If you enter an incorrect sequence, you can unkey before all 8 digits are entered, and the sequence will be ignored. If you enter an incorrect address or incorrect data, just re-program the location affected with the correct data.

In order to save space, reduce keystrokes, and eliminate some software complexity, all programming addresses and data are entered as hexadecimal numbers. Hexadecimal (or hex, for short) is a base-16 notation that is particularly convenient for use in digital computer systems because each hex digit represents 4 bits of a value. The controller uses pairs of hex digits to represent 8-bit values for the address and data of programming information. Any decimal number from 0 to 255 may be represented by two hex digits. Hex digits are 0, 1, 2, 3, 4, 5, 6, 7, 8, 9, A, B, C, D, E, F, where A through F represent values from 10 to 15. To convert a decimal number from 0 to 255 to hex, divide the decimal number by 16. The quotient (number of whole 16s) forms the left (high) digit, and the remainder forms the right (low) digit. Thus, 60 decimal = 3 x 16 + 12 = 3C hex.

The DTMF keys 0-9 and A-D map directly to their corresponding digits.

*Use the * key for digit E and the # key for digit F.*

A 16-key DTMF generator is required to program the controller.

1. Programming the Timers

Timer Resolution. The timer values are stored as an 8-bit value, which allows a range of 0 to 255. Some of the timers require high-resolution timing of short durations, and others require lower resolution timing of longer durations. Therefore, timer values are scaled by either 1/10, 1, or 10 seconds, depending on the application.

NHRC-2 User Guide

Timer Address and Resolution

Timer	Address	Resolution Seconds	Max. Value Seconds
Hang Timer	02	1/10	25.5
Timeout Timer	03	1	255
ID Timer	04	10	2550

Enter the 4 digit passcode, the timer address, and the timer value, scaled appropriately. For example, to program the Hang Timer for 10 seconds, enter *pppp0264*, where *pppp* is your secret passcode, 02 is the hang timer address, and 64 is the hexadecimal value for 100, which would be 10.0 seconds.

2. Programming the CW Messages

CW messages are programmed by storing encoded CW characters into specific addresses in the controller. Use the [Morse Code Character Encoding](#) table and the [Programming Memory Map](#) to determine the data and address for the CW message characters. For example, to program "DE NIKDO/R" for the CW ID, you would use the following commands:

CW ID Programming Example

DTMF Command	Address	Data	Description/Purpose
<i>pppp0#09</i>	0F	09	D
<i>pppp1002</i>	10	02	E
<i>pppp1100</i>	11	00	space
<i>pppp1205</i>	12	05	N
<i>pppp133*</i>	13	3E	1
<i>pppp140D</i>	14	0D	K
<i>pppp1509</i>	15	09	D
<i>pppp160#</i>	16	0F	O

NHRC-2 User Guide

<i>pppp1729</i>	17	29	/
<i>pppp180A</i>	18	0A	R
<i>pppp19##</i>	19	FF	End of message marker

The CW ID can store a message of up to 40 characters. Do not exceed 40 characters.

3. Programming the Flag Bits

Controller features can be enabled or disabled with the use of the Configuration Flag Bits. These bits are encoded into a single byte, which is programmed into the controller at address 01. Multiple flag bits can be selected by summing their hex weights. For instance, to set up a link controller with no ISD1420, no courtesy tone, and suppress the DTMF muting, you would add 01, 10, and 20 to produce hex 31, which you would then program into address 01 in the controller as *pppp0131*.

Configuration Flag Bits

Bit	Hex Weight	Feature
0	01	ISD Absent
1	02	Simplex repeater mode
2	04	n/a
3	08	n/a
4	10	suppress courtesy tone
5	20	suppress DTMF muting
6	40	use tail message for courtesy tone
7	80	n/a

4. Recording the Voice Messages

Stored voice messages can be played and recorded, and CW messages can be played by using the message commands. Command 40 is used to play

stored voice or CW messages, and command 41 is used to record stored voice messages.

To record stored voice messages, use command *pppp410x*, where *x* is the number of the message you want to record, found in the message contents table. Unkey after the command sequence, then key up, speak your message, and unkey. The controller will remove about 100 ms from the end of your message to remove any squelch crash that might have been recorded.

To play stored voice messages, use command *pppp401x*, where *x* is the number of the stored voice message you want to play. To play CW messages, use command *pppp401x*, where *x* is the number of the CW message you want to play.

You may wish to have a family member or member of the opposite sex record your ID messages. The recorded audio sounds natural enough that people have actually tried to call the amateur whose callsign is recorded in the controller after the ID message plays!

3. Enabling/Disabling the Repeater

The repeater can be disabled or enabled by remote control by setting the value in location 00. Set this location to zero to disable, or non-zero to enable. For instance, to disable the repeater, send command *pppp0000*. To enable the repeater, send command *pppp0001*.

3. Operating

1. About the IDs

When the repeater is first keyed the controller will play the "initial ID". If the repeater is keyed again before the ID timer expires, the controller will play the "normal ID" when the ID timer expires. If the repeater is not keyed again, and the ID timer expires, the controller will reset and play the "initial ID" the next time the repeater is keyed. If the repeater is keyed while the controller is playing a stored voice message ID, the controller will cancel the stored voice message ID and play the CW ID.

The idea behind this IDing logic is to prevent unnecessary IDing. For instance, if a repeater user keys the machine and announces "This is N1KDO, monitoring", the controller will play the initial ID, and no further IDing will occur unless the repeater is keyed again. If users commence with a QSO, keying the repeater at least once more, the controller will play the normal ID and reset the ID timer when the ID timer expires. If the repeater becomes idle for one ID timer period after the last ID, then the next time it is keyed it will play the initial ID. The

intent is that the repeater users only hear the initial ID the first time that they key the repeater.

2. The Tail Message

The controller supports a "Tail Message" that plays the n th time the hang timer expires. The number of times the hang timer must expire before the tail message plays (n) is the "tail message counter" at address 5. The tail message counter can be set from 1 to 255. The tail message is disabled if the tail message counter is set to 0. Program the tail message counter value into address 05.

3. Using the Tail Message as the Courtesy Tone

The tail message can be used as the courtesy tone if bit 6 is set in the configuration flags. In this case, you will likely want to set the tail message counter value to 0 to keep the message from playing twice occasionally. The message could store the sound of a bell, a dog's bark, or the repeater trustee saying "what?!"

Tables

Message Commands

Command	Description
400x	$0 \leq x \leq 3$, play CW message x
401x	$0 \leq x \leq 3$, play voice message x
410x	$0 \leq x \leq 3$, record voice message x

Message Contents

Message Number	Stored Voice	CW
0	Initial ID	ID message
1	Normal ID message	timeout message ("TO")
2	Time-out Message	confirm message ("OK")
3	Tail Message	invalid message ("NG")

NHRC-2 User Guide

Programming Memory Map

Address	Default Data	Comment
00	01	enable flag
01	00	configuration flags
02	32	hang timer preset, in tenths
03	1e	time-out timer preset, in seconds
04	36	id timer preset, in 10 seconds
05	00	tail message counter
06	0f	'O' OK Message
07	0d	'K'
08	ff	EOM
09	05	'N' NG Message
0a	0b	'G'
0b	ff	EOM
0c	03	'T' TO Message
0d	0f	'O'
0e	ff	EOM
0f	09	'D' CW ID starts here
10	02	'E'
11	00	space
12	05	'N'
13	3e	'I'
14	0d	'K'

NHRC-2 User Guide

15	09	'D'
16	0f	'O'
17	29	'/'
18	0a	'R'
19	ff	EOM
1a	00	can fit 6 letter ID....
1b-37		not used
38	n/a	isd message 0 length, in tenths
39	n/a	isd message 1 length, in tenths
3a	n/a	isd message 2 length, in tenths
3b	n/a	isd message 3 length, in tenths
3c	n/a	passcode digit 1
3d	n/a	passcode digit 2
3e	n/a	passcode digit 3
3f	n/a	passcode digit 4

NHRC-2 User Guide

Morse Code Character Encoding

Character	Morse Code	Binary Encoding	Hex Encoding
sk	. . . - . -	01101000	68
ar	. - . - .	00101010	2a
bt	- . . . -	00110001	31
/	- . . - .	00101001	29
0	- - - - -	00111111	3f
1	. - - - -	00111110	3e
2	. . - - -	00111100	3c
3	. . . - -	00111000	38
4 -	00110000	30
5	00100000	20
6	-	00100001	21
7	- - . . .	00100011	23
8	- - - . .	00100111	27
9	- - - - .	00101111	2f
a	. -	00000110	06
b	- . . .	00010001	11
c	- . - .	00010101	15
d	- . .	00001001	09
e	.	00000010	02
f	. . - .	00010100	14
g	- - .	00001011	0b

NHRC-2 User Guide

h	00010000	10
i	. .	00000100	04
j	. - - -	00011110	1e
k	- . -	00001101	0d
l	. - . .	00010010	12
m	- -	00000111	07
n	- .	00000101	05
o	- - -	00001111	0f
p	. - - .	00010110	16
q	- - . -	00011011	1b
r	. - .	00001010	0a
s	. . .	00001000	08
t	-	00000011	03
u	. . -	00001100	0c
v	. . . -	00011000	18
w	. - -	00001110	0e
x	- . . -	00011001	19
y	- . - -	00011101	1d
z	- - . .	00010011	13
space		00000000	00
EOM		11111111	ff

NHRC-2 Repeater Controller

Assembly Guide

Rev D PCB only

The NHRC-2 Repeater Controller is a fairly simple project to build. Minimal electronic experience is required. Assembly time should be around 1 hour.

1. Organize your parts as per the Bill of Materials. All resistors in this kit are mounted vertically on the PCB. You may want to form the resistor leads ahead of time. Simply bend the resistor lead over. (*Hint:* Try to keep the color code bands consistent top to bottom throughout the board, oriented such that the tolerance bands of the resistors all face in the same direction). Note that pin 1 of many components is denoted by the square pad on the PCB. You will be working from your parts list and matching components from the parts list to their appropriate location on the PCB. As you install a part check it off on your parts list. You can also use the “Board Layout” image located on page 2 of your User Guide as a reference for parts placement.
2. Insert the capacitors into the PCB. Be careful to install the polarized caps correctly. The square pad always goes to the positive (+) lead of the capacitor. Capacitors such as the 0.1uF bypass caps are non-polarized and do not have a square pad. They may be inserted either way. (*Note:* Double check your work, tantalum capacitors may explode upon power up if they are inserted backwards. Be careful not to mix up C20 (33pF) with any of your bypass caps, they look similar.)
3. Insert the resistors. The PCB silkscreen has a circle around the pad that the resistor body will sit above and a line from the circle indicates where the other lead goes. Be careful to match the reference designator to the proper component location. If in doubt find the component in the schematic and use an ohmmeter to identify the component location in question. Some reference designators may be crowded among other reference designators and may have a line drawn to the proper component location. (*Note:* Pay special attention to the placement of resistors R4 and R11. Resistor R4 is located next to C3 and R11 is located next to C8.)
4. Install the voltage regulator, U4 (LM7805) and power MOSFET Q6 (IRF510). All of these components are installed with the heat sink surface facing out from the board. (*Note:* These parts should not require mounting to a heat sink.)
5. Install the other transistors and FET's. Q2, Q3, and Q4 are PN2222, Q1 is an MPF102 JFET, and Q5, which is a 2N3906.
6. Install the zener diode, D1 (1N5226) so that the cathode (the end with the band) goes into the square pad. (*Note:* Zener diode D2 (1N5240) does not need to be installed.)

NHRC-2 User Guide

7. Install the crystal, Y1, being careful not to have the part body contact the trace below it. Lifting Y1 up slightly off the PCB or using a dab of RTV or "hot glue" under the part before soldering will solve this.
8. Install pots, VR1, VR3, VR4, VR5 & VR6 which are 10K (marked "103") and VR2 which is 500K (marked "504").
9. Install connector P1, and 2 pin header SW1.
10. Install the chip sockets. (*Note:* Install them so that designator for pin 1 is per the notch shown on this chip socket on the silkscreen.) **Do not install your chips at this time.** You will need to do some power up checks first.
11. Solder all of your connections using a small soldering iron of approx. 25-40 watts. (DO NOT USE A SOLDERING GUN). Use a "63/37" rosin flux-core solder and use care not to overheat the PCB. Carefully trim the leads of the bottom of the PCB. Clean the PCB to remove flux residue with alcohol. You may also consider using a water-soluble flux-core solder (such as Alpha Metals Aqualine 6000). A quick rinse under warm water in your sink after assembly and your finished product will look professional.
12. Double-check your work. Check for any unsoldered parts, solder bridges, or improper part placement.

You are now ready to apply power to the PCB and check some voltages before installing the IC chips. See the Users Guide for assistance with assembly of the connections required. Apply power and check that the +5V regulator is working and that +5 volts (VCC) is being supplied where needed (*Example:* U1 pin 14, U2 pins 16 & 28, etc.). Check that VREF is approximately 1/2 of your input supply voltage is at U5 pins 3 & 5. When you are confident that all of your voltages are OK then you are ready to install your chips. After which you can power the PCB back up, INIT the processor (following the procedure in the Users Guide) and enjoy!

If you encounter problems go back and recheck your work, look for unsoldered connections, solder bridges or misplaced components.

Look at the Assembly FAQ and the Troubleshooting Guide included in the Users Guide or visit the NHRC-2 web site <http://www.nhrc.net/nhrc2> for more detailed trouble shooting instructions. We also offer troubleshooting support by email hardware@nhrc.net. The circuit is fairly simple and most problems can be resolved quickly.

Alpha Metals solder info is available at <http://www.alphametals.com>

NHRC-2 Repeater Controller

Frequently Asked Questions about Assembling a Partial Kit

Rev D PCB only

I have some ISD1020s lying around. Can I use them in the NHRC-2?

Not easily. The ISD1000 series parts use a slightly different interface for record/play, power down, and chip select. To use an ISD1000 series part would require some changes to the PC board, and some software changes as well. These changes are not impossible, in fact the original prototype controller used an ISD1020, but the ISD1420 is a less expensive, newer part.

What if Digi-Key is out of stock of the DB9 connector?

If the NorComp part listed in the BOM is unavailable, Digi-Key does not offer a good sub. Two acceptable subs are: Newark Electronics P/N: 87F2251 (Amphenol 617-C009S-AJ120 \$0.98ea.) or RadioShack P/N: 910-1546 (\$1.90ea.) These devices have the proper offset (0.318") and board mount locks, however neither part comes with jackscrews. These are available separately using Newark P/N: 50F4689 (Keystone 7228 \$0.24ea.) Some kit builders have reported that the AMP Amplimite 754781-4 (Digikey A2100-ND), will fit in the board, but extreme care must be taken if this part is used to make sure that none of the traces on the PC board under the connector are shorted out. Use some electrical tape or Mylar sheet to insulate the connector housing from the board.

I built my controller, and it doesn't work. What can I do?

Look at the Troubleshoot Guide contained in your documentation or the Troubleshooting Information page at <http://www.nhrc.net/nhrc2/troubles.html> for some ideas to get your controller running.

I want to build a controller without the ISD1420, because I don't desire speech or for use as a link controller. What parts are not needed?

You can leave the following parts off the board:

C5, C9, C12, C15, C18, C23, C24, C25
Q3, Q4
R9, R10, R13, R20, R21, R24, R25, R26, R27, R28
U2
VR3, VR5

Remember to set bit 0 of the configuration flag to indicate to the microprocessor that the ISD1420 is not present. Consider setting bits 4 and 5 as well, depending on

your linking requirements.

What's all this about de-emphasis, and why should I care?

De-emphasis is used to remove the pre-emphasis put on a FM signal by the transmitter. Together, they work to reduce the amount of hiss you hear in a received FM signal. The concept is similar to Dolby noise reduction: the transmitted signal has the high-frequency component boosted before transmission, and then a corresponding reduction occurs in the receiver. The receiver removing a significant part of the high-frequency component of the received signal actually removes a lot of hiss and noise with it.

If you use receiver audio that has not been de-emphasized (like what is commonly found on the high side of the squelch control), then the repeated audio will sound very tinny and unnatural. However, the high side of the squelch control is a good place to take audio from a receiver used in a repeater because the audio there is not subject to level changes caused by the volume control. In many radios, the de-emphasis filter is "downstream" of the volume control, which makes taking audio from there unattractive.

The NHRC-2 has the capability to perform de-emphasis filtering on board. To use the onboard filter, some parts substitutions must be performed. It is probably easier to decide whether you want the filter or not *before* soldering part to the board.

Component	No De-emphasis	With De-emphasis
C3	Not present	.0068uF
R3	100K	51K
R4	100K	510K

I seem to be “falseing” the DTMF decoder frequently. What’s the problem?

First try adjusting the level of VR1 (RX LVL) down. If the signal level is too high it could be overloading the decoder. You can also try replacing R22 (300K) with a 470K ohm resistor. This speeds up the time constant of the DTMF decoder slightly, and should help eliminate “falseing”.

There seems to be some distortion in the repeated audio. What can I do?

Try replacing U5 (the LM358) with a TL062CP (available from Digi-Key P/N: 296-1771-5-ND), or install a 4.7K resistor from U5 pin 7 to ground. Do not use both modifications.

NHRC-2 Repeater Controller

Troubleshooting Guide

Rev D PCB Only

Power-related problems

Check all of your solder joints carefully. A poorly soldered or an unsoldered joint can cause all sorts of problems. Solder joints should appear bright and shiny, and the solder should taper from the end of the pin to the pad on the board; there should not be a "blob" of solder on the pin. Make sure that there are no solder "bridges" between pads or traces. It is very easy to create solder bridges between the IC pins; these pins are only 1/10 inch apart.

Apply power with all the chips removed from their sockets and an ammeter in series with the +12 volts (pin 2 of P1 on the controller). There should be an extremely small amount of current flowing into the board with the IC's removed, typically less than 5mA. If there is more current, check component placement, and ensure that there are no solder bridges on the board. Remove the ammeter, and re-apply power. With all of the chips still removed, check for +5 volts at pin 3 of U4 (LM7805), pin 14 of U1 (PIC16F84), pin 28 of U2 (ISD1420), and pin 18 of U3 (M8870). If any of the power supply voltages are not right **do not insert the chips** until this problem is found and corrected.

Make sure the PIC16F84 is in the correct socket on the board. The M8870 sits in the socket nearest to the crystal. Make sure the chips are plugged in correctly, with pin 1 corresponding with the square pad on the PCB. Improper installation of the chips can destroy them! If you had any of the chips in backward they may be "nuked".

CAS Signal problems

The easiest way to verify correct operation of the CAS signal is to remove ISO1 (4N36) from its socket, and plug a LED in instead. The LED's anode (the "+" leg, usually longer) goes into pin 1, and the cathode (the "-" leg, usually shorter) goes to pin 2 of the socket. If you are unsure of which leg of the LED is which, test it with +12 volts and a 1Kohm resistor in series with the LED. When the CAS signal is correctly applied, the LED should glow. A dim glow is probably OK. If the LED lights up very brightly, or "smokes", it is likely that the CAS signal's voltage is too

high. In this case, ISO1 has probably been destroyed. Replace R30 (1.5Kohms) with a higher value, calculated to allow approximately 10mA to flow through the LED in the opto-isolator. We do not recommend CAS signal voltages of more than 30 volts.

If the LED will not glow, make sure that there is at least +3 volts on pin 6 of the DB9 connector (P1), measured against pin 7, when the CAS signal is present. The LED must glow when the CAS signal is present.

If the LED glows when CAS is applied, but the controller never seems to "see" that the signal is there, you can test the entire CAS path in the controller by using a DVM to measure the voltage on pin 13 of U1 (PIC16F84). Pin 13 should be near +5 volts when the CAS signal is not present, and should fall to near 0 volts when the signal is present.

PTT Signal problems

If the power is not good, or the CAS signal is not good, you will never get PTT (push-to-talk). These sections should be verified before worrying about the PTT circuit.

Pin 7 of U1 (PIC16F84) should normally be around 0 volts, and should rise to about +5 volts when the controller turns PTT on. If not, verify the CAS signal is working, then examine the section in this document on a completely dead controller. When PTT is turned on, the gate (pin 1) of Q6 should rise to about +5 volts. If not, then either Q6 is bad (shorted) or R29 is open or incorrectly installed.

The controller supplies PTT as a closure to ground. If the controller is interfaced to the repeater correctly, there should be some positive voltage on the drain (pin 2) of Q6. When the controller turns PTT on, this positive voltage should drop to near 0 volts. If there is no positive voltage on pin 2 of Q6, then check the interface to the transmitter's PTT line.

Completely Dead Controller

If the controller appears completely dead, and none of the power, CAS, or PTT symptoms are found, then the problem may be related to the microprocessor. Measure the DC voltage on Pin 4 of U1 (PIC16F84) with a DVM. This pin should have around +5 volts on it. If it does not, check R17, R18, R19, Q5, and D1. Make sure that D1 is installed correctly, with the banded end of the diode mounted into the square pad on the PCB. Make sure that Q5 is oriented correctly, and verify the values of R17, R18, and R19.

If U1 pin 4 has about +5 volts on it, make sure that the 3.58 MHz clock is running. Use an oscilloscope to look at U1 pin 15. This pin should have a

nice square wave on it, at the 3.58 MHz clock frequency. If the clock is not found at pin 15, look for it at U3 (M8870) pin 8. If the clock is present on U3 pin 8, but not on U1 pin 15, verify the installation of C20, a 33pF capacitor. If the clock is not present on U3 pin 8, verify that power is applied to the U3, that the crystal Y1 is properly installed and that the crystal is not shorting from the case to the trace just under it. Lifting Y1 up slightly off the PCB or using a dab of RTV or "hot glue" under the part will correct this.

Audio problems

First, note that the controller should pass audio through to the transmitter only when the CAS signal is present. If the audio passes through when the CAS signal is not present, and un-squelched audio is transmitted during the hang time, then it is likely that either you have forgotten to remove the "INIT" jumper (SW1), or are overdriving the audio gate FET. Remove the jumper or reduce the signal applied with VR1.

The next common problem to cause the audio path to malfunction is the failure to use dipped tantalum caps for C2, C7, C8, C9, C10, C11, C14 and C17. The tantalum caps have a very low ESR (effective series resistance). The use of any other type of cap will cause the output of the op amp to sit at the rail (+12v). Voltages around U5 (LM358) measured with a DVM should be as follows: Pin 3 = +6.5v, Pin 1 = +6.5v, Pin 7 = +6.5v. If pin 1 or 7 is reading higher (about +12 volts or more) you have a leaky cap or an open in the feedback path. If pin 3 isn't reading around +6.5v check the values of R1 and R2, should be 10Kohms. Also note that you have installed the tantalum caps in the board with the proper polarity. The square pad indicates the positive side of the cap. Reverse voltages easily destroy tantalum caps, if you put it in backwards, throw it away and use a new one.

If the audio out of the controller is low, check to make sure that VR2 is a 500Kohm pot and R15 is 10Kohms.

DTMF decoding problems

If DTMF tones do not mute completely or not at all, try lowering the level at VR1 (RX LVL). You may be over-driving the audio muting gate FET (Q1) and it is starting to turn on. Verify the installation of all the components in the muting circuit: R6, R7, R8, Q1, and Q2.

If DTMF tones do not mute and the controller doesn't respond to commands, can't load password, make certain that VR1 isn't adjusted to low. You should have around +2v P-P at U5 pin 1, ignoring the DC level. Check the audio circuit for malfunctions as above. If the audio through

the controller is good check that C1, a 0.1uF cap is soldered in. R5 and R23 should be 100Kohms. Look with a scope at pin 2 on U3 (M8870). You should see audio here. It should look similar to the signal at U5 (LM358) pin 1 EXCEPT the signal should not be biased at the +6.5v DC level. If you have audio at a DC level at the decoder pin 2 then C1 is probably bad. If the audio looks good at the decoder be certain R22 is 300Kohms and C19 is 0.1uF. Probe pin 15 (STD) of U3 with a DVM or scope, you should see this pin go high when you send DTMF to the controller. If the STD signal is working check pin 6 of U1 (PIC16F84) and see if the signal is getting to the PIC.

Check the section on audio problems if this section does not help with your DTMF decoding problem.

Voice messages are distorted or noisy

The leading cause of noise on recorded messages is improper bypass caps on the power supply leads around the 7805 and the ISD1420. Be certain that C13 is installed properly and is a minimum of 220uF@16v. The ISD1420 draws large bursts of current while recording. If the caps are not properly installed the voltage to the chip sags during record and noise is recorded with the audio.

If your messages are distorted you are probably either overdriving the ISD1420, or the ISD1420 is overdriving the repeater controller's mixer or your transmitter's microphone preamp. Place the controller in the simplex repeater mode and adjust VR3 (RECORD LVL) and VR5 (SPEECH LVL) until the audio sounds natural.

Also check the values of R21 (470Kohms), C12 (4.7uF tantalum cap), and C10 (0.1uF). Check R9 (22Kohms), R10 (10Kohms) and C5 (0.1uF). Check C9 (1uF tantalum), R13 (22Kohms).

The last resort...

If these hints don't get you going or don't address your problem, then send a detailed, clearly written question to hardware@nhrc.net. Also, please email if you discover a problem, hint, or solution that is not documented in this page.

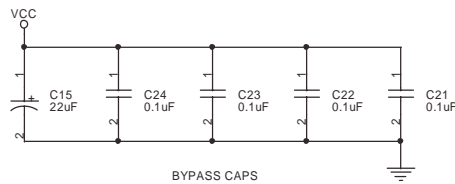
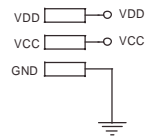
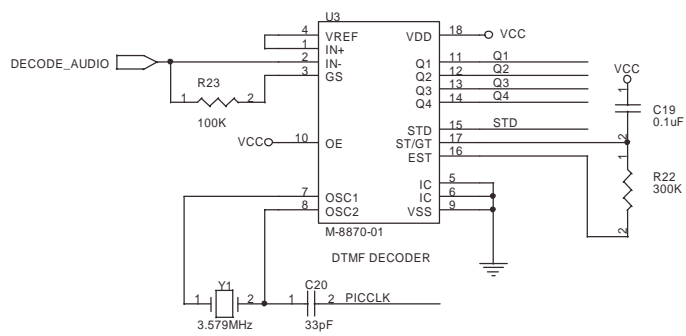
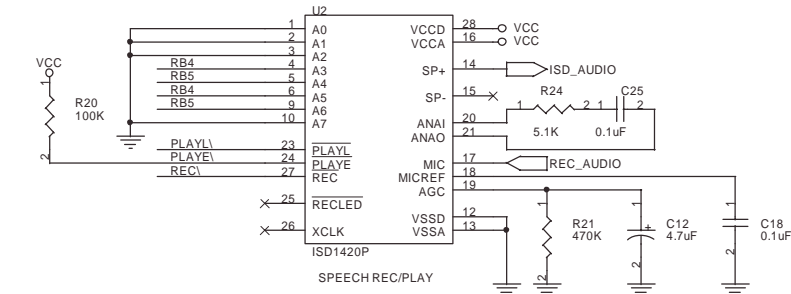
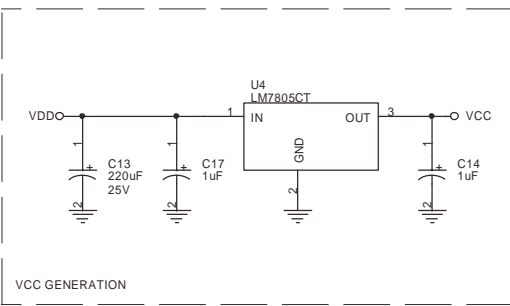
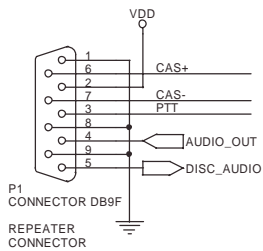
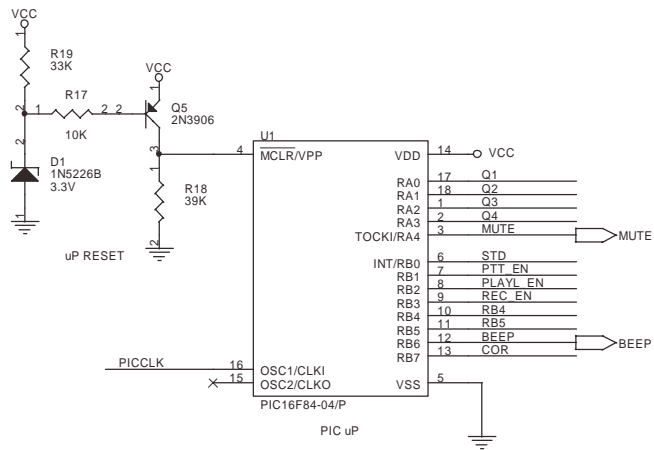

NOTES:

1. ALL RESISTORS ARE 1/4W 5% TOL. UNLESS OTHERWISE STATED.

2. ALL CAPACITORS ARE 16V ELECTROLYTIC / 50V CERAMIC UNLESS OTHERWISE STATED.

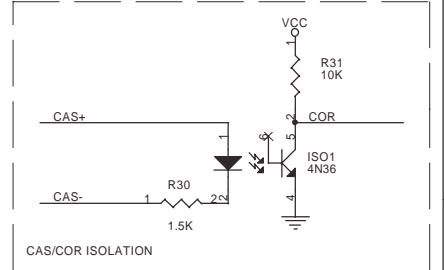
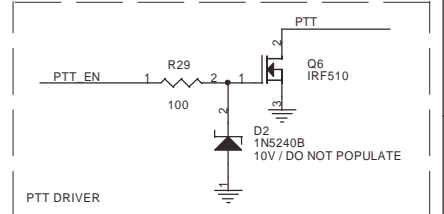
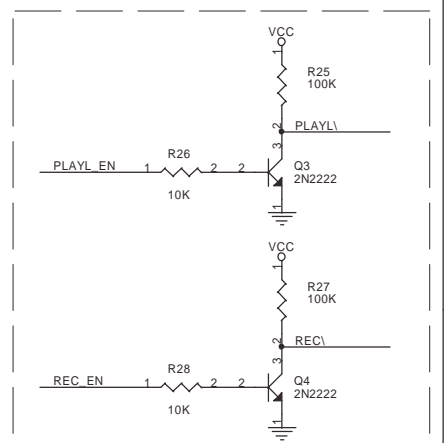

NOTICE

THIS DRAWING CONTAINS PROPRIETARY INFORMATION WHICH IS THE CONFIDENTIAL PROPERTY OF NHRC LLC. IT SHALL NOT BE COPIED, REPRODUCED, DISCLOSED, PUBLISHED OR USED IN PART OR WHOLE WITHOUT THE EXPRESSED WRITTEN PERMISSION OF NHRC LLC. SPECIFICATIONS SUBJECT TO CHANGE WITHOUT NOTICE OR OBLIGATION.

PCB REV D

NHRC Repeater Controllers

444 Micol Road
Pembroke, NH 03275
603-485-2248
<http://www.nhrc.net>

Title NHRC-2 (Digital) DRAWN BY: N1LTL

Size B	Document Number	Rev B
--------	-----------------	-------

Date: Monday, February 28, 2000 Sheet 1 of 2

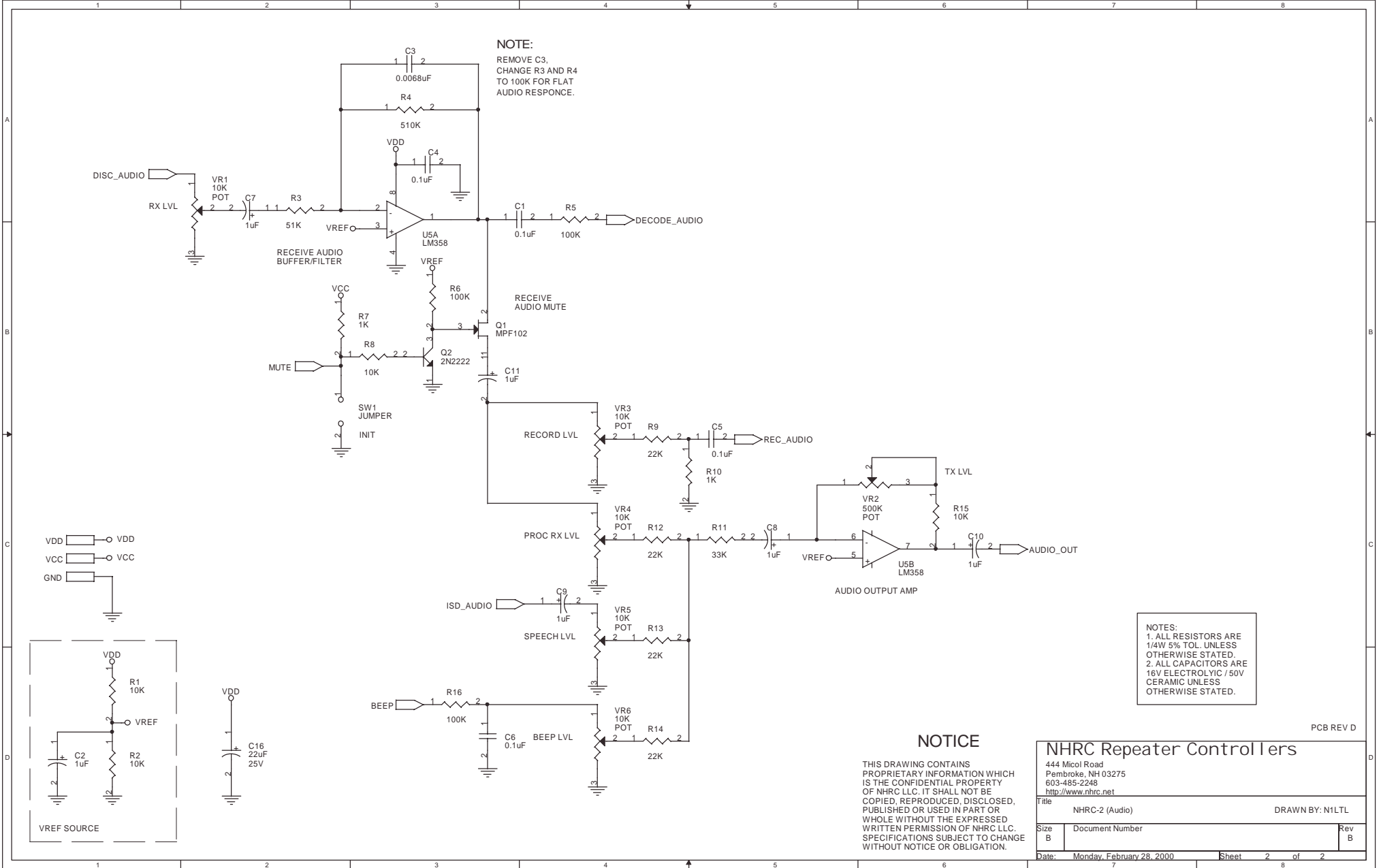

NHRC Repeater Control Iers 444 Micol Road Pembroke, NH 03275 603-485-2248 http://www.nhrc.net		
Title	NHRC-2 (Audio)	DRAWN BY: N1LTL
Size	Document Number	Rev
B		B
Date:	Monday, February 28, 2000	Sheet 2 of 2

NHRC-2 Repeater Controller BOM for PCB rev D only

Item	Qty.	Ref.	Value	Description	Mfg.	Mfg. P/N	Digi-Key P/N	Unit Cost	Notes
1	11	C1	0.1uF	0.1uF 50V Z5U Ceramic Capacitor	Panasonic	ECU-S1H104MEA	P4924-ND	\$ 0.43	
		C4	0.1uF	0.1uF 50V Z5U Ceramic Capacitor	Panasonic	ECU-S1H104MEA	P4924-ND	\$ 0.43	
		C5	0.1uF	0.1uF 50V Z5U Ceramic Capacitor	Panasonic	ECU-S1H104MEA	P4924-ND	\$ 0.43	
		C6	0.1uF	0.1uF 50V Z5U Ceramic Capacitor	Panasonic	ECU-S1H104MEA	P4924-ND	\$ 0.43	
		C18	0.1uF	0.1uF 50V Z5U Ceramic Capacitor	Panasonic	ECU-S1H104MEA	P4924-ND	\$ 0.43	
		C19	0.1uF	0.1uF 50V Z5U Ceramic Capacitor	Panasonic	ECU-S1H104MEA	P4924-ND	\$ 0.43	
		C21	0.1uF	0.1uF 50V Z5U Ceramic Capacitor	Panasonic	ECU-S1H104MEA	P4924-ND	\$ 0.43	
		C22	0.1uF	0.1uF 50V Z5U Ceramic Capacitor	Panasonic	ECU-S1H104MEA	P4924-ND	\$ 0.43	
		C23	0.1uF	0.1uF 50V Z5U Ceramic Capacitor	Panasonic	ECU-S1H104MEA	P4924-ND	\$ 0.43	
		C24	0.1uF	0.1uF 50V Z5U Ceramic Capacitor	Panasonic	ECU-S1H104MEA	P4924-ND	\$ 0.43	
		C25	0.1uF	0.1uF 50V Z5U Ceramic Capacitor	Panasonic	ECU-S1H104MEA	P4924-ND	\$ 0.43	
2	8	C2	1uF	1.0uF 16V Solid Tantalum Capacitor	Panasonic	ECS-F1CE105K	P2105-ND	\$ 0.42	
		C14	1uF	1.0uF 16V Solid Tantalum Capacitor	Panasonic	ECS-F1CE105K	P2105-ND	\$ 0.42	
		C17	1uF	1.0uF 16V Solid Tantalum Capacitor	Panasonic	ECS-F1CE105K	P2105-ND	\$ 0.42	
		C7	1uF	1.0uF 16V Solid Tantalum Capacitor	Panasonic	ECS-F1CE105K	P2105-ND	\$ 0.42	
		C8	1uF	1.0uF 16V Solid Tantalum Capacitor	Panasonic	ECS-F1CE105K	P2105-ND	\$ 0.42	
		C9	1uF	1.0uF 16V Solid Tantalum Capacitor	Panasonic	ECS-F1CE105K	P2105-ND	\$ 0.42	
		C10	1uF	1.0uF 16V Solid Tantalum Capacitor	Panasonic	ECS-F1CE105K	P2105-ND	\$ 0.42	
		C11	1uF	1.0uF 16V Solid Tantalum Capacitor	Panasonic	ECS-F1CE105K	P2105-ND	\$ 0.42	
3	1	C3	0.0068uF	0.0068uF 50V X7R Ceramic Capacitor	Panasonic	ECU-S1H682KBA	P4951-ND	\$ 0.35	see note 1
4	1	C12	4.7uF	4.7uF 50V Aluminum Electrolytic Cap	Panasonic	ECA-1HM4R7	P5177-ND	\$ 0.21	
5	1	C13	220uF	220uF 25V Aluminum Electrolytic Cap	Panasonic	ECA-1EM221	P5153-ND	\$ 0.41	
6	2	C15	22uF	22uF 25V Aluminum Electrolytic Cap	Panasonic	ECA-1EM220	P5149-ND	\$ 0.21	
		C16	22uF	22uF 25V Aluminum Electrolytic Cap	Panasonic	ECA-1EM220	P5149-ND	\$ 0.21	
7	1	C20	33pF	33pF 100V COG Ceramic Capacitor	Panasonic	ECU-S2A330JCA	P4843-ND	\$ 0.38	
8	1	D1	1N5226B	3.3V 500mW Zener Diode	Diodes Inc.	1N5226B	1N5226BCT-ND	\$ 0.36	
9	1	D2	1N5240B	10V 500mW Zener Diode	Diodes Inc.	1N5240B	N/A		not installed
10	1	ISO1	4N36	Opto Isolator w/Photo Transistor Output	Quality Tech	4N36	4N36QT-ND	\$ 0.50	
11	1	P1	CONN. DB9F	9 Pin Female D-Sub Right Angle Connector	NorComp	182-009-212-531	182-09F-ND	\$ 0.81	
12	1	PCB1		NHRC-2 Repeater Controller PCB	NHRC	NHRC-2 PCB rev D	N/A		see note 2
13	1	Q1	MPF102	N-Channel JFET	Fairchild	MPF102	MPF102-ND	\$ 0.49	
14	3	Q2	2N2222	NPN Transistor	Fairchild	PN2222	PN2222-ND	\$ 0.26	
		Q3	2N2222	NPN Transistor	Fairchild	PN2222	PN2222-ND	\$ 0.26	
		Q4	2N2222	NPN Transistor	Fairchild	PN2222	PN2222-ND	\$ 0.26	
15	1	Q5	2N3906	PNP Transistor	Fairchild	2N3906	2N3906-ND	\$ 0.26	
16	1	Q6	IRF510	N-Channel Logic Level MOSFET	IRF	IRF510	IRF510-ND	\$ 0.77	
17	8	R1	10K	10K 5% 1/4W Carbon Film Resistor	Yaego	CFR-25JB 10K	10KQBK-ND	\$ 0.06	
		R2	10K	10K 5% 1/4W Carbon Film Resistor	Yaego	CFR-25JB 10K	10KQBK-ND	\$ 0.06	
		R8	10K	10K 5% 1/4W Carbon Film Resistor	Yaego	CFR-25JB 10K	10KQBK-ND	\$ 0.06	
		R15	10K	10K 5% 1/4W Carbon Film Resistor	Yaego	CFR-25JB 10K	10KQBK-ND	\$ 0.06	
		R17	10K	10K 5% 1/4W Carbon Film Resistor	Yaego	CFR-25JB 10K	10KQBK-ND	\$ 0.06	
		R26	10K	10K 5% 1/4W Carbon Film Resistor	Yaego	CFR-25JB 10K	10KQBK-ND	\$ 0.06	
		R28	10K	10K 5% 1/4W Carbon Film Resistor	Yaego	CFR-25JB 10K	10KQBK-ND	\$ 0.06	
		R31	10K	10K 5% 1/4W Carbon Film Resistor	Yaego	CFR-25JB 10K	10KQBK-ND	\$ 0.06	
18	1	R3	51K	51K 5% 1/4W Carbon Film Resistor	Yaego	CFR-25JB 51K	51KQBK-ND	\$ 0.06	see note 1

NHRC-2 Repeater Controller BOM for PCB rev D only

Item	Qty.	Ref.	Value	Description	Mfg.	Mfg. P/N	Digi-Key P/N	Unit Cost	Notes
19	1	R4	510K	510K 5% 1/4W Carbon Film Resistor	Yaego	CFR-25JB 510K	510KQBK-ND	\$ 0.06	see note 1
20	7	R5	100K	100K 5% 1/4W Carbon Film Resistor	Yaego	CFR-25JB 100K	100KQBK-ND	\$ 0.06	
		R6	100K	100K 5% 1/4W Carbon Film Resistor	Yaego	CFR-25JB 100K	100KQBK-ND	\$ 0.06	
		R16	100K	100K 5% 1/4W Carbon Film Resistor	Yaego	CFR-25JB 100K	100KQBK-ND	\$ 0.06	
		R20	100K	100K 5% 1/4W Carbon Film Resistor	Yaego	CFR-25JB 100K	100KQBK-ND	\$ 0.06	
		R23	100K	100K 5% 1/4W Carbon Film Resistor	Yaego	CFR-25JB 100K	100KQBK-ND	\$ 0.06	
		R25	100K	100K 5% 1/4W Carbon Film Resistor	Yaego	CFR-25JB 100K	100KQBK-ND	\$ 0.06	
		R27	100K	100K 5% 1/4W Carbon Film Resistor	Yaego	CFR-25JB 100K	100KQBK-ND	\$ 0.06	
21	2	R7	1K	1K 5% 1/4W Carbon Film Resistor	Yaego	CFR-25JB 1K0	1.0KQBK-ND	\$ 0.06	
		R10	1K	1K 5% 1/4W Carbon Film Resistor	Yaego	CFR-25JB 1K0	1.0KQBK-ND	\$ 0.06	
22	4	R9	22K	22K 5% 1/4W Carbon Film Resistor	Yaego	CFR-25JB 22K	22KQBK-ND	\$ 0.06	
		R12	22K	22K 5% 1/4W Carbon Film Resistor	Yaego	CFR-25JB 22K	22KQBK-ND	\$ 0.06	
		R13	22K	22K 5% 1/4W Carbon Film Resistor	Yaego	CFR-25JB 22K	22KQBK-ND	\$ 0.06	
		R14	22K	22K 5% 1/4W Carbon Film Resistor	Yaego	CFR-25JB 22K	22KQBK-ND	\$ 0.06	
23	2	R11	33K	33K 5% 1/4W Carbon Film Resistor	Yaego	CFR-25JB 33K	33KQBK-ND	\$ 0.06	
		R19	33K	33K 5% 1/4W Carbon Film Resistor	Yaego	CFR-25JB 33K	33KQBK-ND	\$ 0.06	
24	1	R18	39K	39K 5% 1/4W Carbon Film Resistor	Yaego	CFR-25JB 39K	39KQBK-ND	\$ 0.06	
25	1	R21	470K	470K 5% 1/4W Carbon Film Resistor	Yaego	CFR-25JB 470K	470KQBK-ND	\$ 0.06	
26	1	R22	300K	300K 5% 1/4W Carbon Film Resistor	Yaego	CFR-25JB 300K	300KQBK-ND	\$ 0.06	
27	1	R24	5.1K	5.1K 5% 1/4W Carbon Film Resistor	Yaego	CFR-25JB 5K1	5.1KQBK-ND	\$ 0.06	
28	1	R29	100	100 5% 1/4W Carbon Film Resistor	Yaego	CFR-25JB 100R	100QBK-ND	\$ 0.06	
29	1	R30	1.5K	1.5K 5% 1/4W Carbon Film Resistor	Yaego	CFR-25JB 1K5	1.5KQBK-ND	\$ 0.06	
30	1	SKT1		8 pin DIP socket	Assmann	A08-LC-TT	AE8908-ND	\$ 0.29	
31	2	SKT2		18 pin DIP socket	Assmann	A18-LC-TT	AE8918-ND	\$ 0.41	
		SKT3		18 pin DIP socket	Assmann	A18-LC-TT	AE8918-ND	\$ 0.41	
32	1	SKT4		28 pin DIP socket	Assmann	A28-LC-TT	AE8928-ND	\$ 0.63	
33	1	SKT5		6 pin DIP socket	Assmann	A06-LC-TT	AE8906-ND	\$ 0.27	
34	1	SW1	SW PB	2 Pin 0.100" Center Header	Molex	22-03-2021	WM4000-ND	\$ 0.25	
35	1	U1	PIC16F84-04/P	8 Bit RISC Microcontroller	Microchip	PIC16F84-04/P	PIC16F84-04/P-ND	\$ 6.88	see note 2
36	1	U2	ISD1420P	Single-Chip Voice Record/Playback	ISD	ISD1420P	ISD1420P-ND	\$ 5.63	
37	1	U3	M-8870-01	DTMF Decoder	Teltone	M8870-01	N/A		see note 2
38	1	U4	LM7805CT	5V 1.5A Voltage Regulator	Nat'l Semi	LM340T-5	LM340T-5.0-ND	\$ 0.90	
39	1	U5	LM358	Dual Low Power Op-Amp	Nat'l Semi	LM358AN	LM358N-ND	\$ 0.59	
40	5	VR1	10K	10K 6mm Single Turn Cermet Pot	Panasonic	EVN-36GA00B14	36G14-ND	\$ 0.56	
		VR3	10K	10K 6mm Single Turn Cermet Pot	Panasonic	EVN-36GA00B14	36G14-ND	\$ 0.56	
		VR4	10K	10K 6mm Single Turn Cermet Pot	Panasonic	EVN-36GA00B14	36G14-ND	\$ 0.56	
		VR5	10K	10K 6mm Single Turn Cermet Pot	Panasonic	EVN-36GA00B14	36G14-ND	\$ 0.56	
		VR6	10K	10K 6mm Single Turn Cermet Pot	Panasonic	EVN-36GA00B14	36G14-ND	\$ 0.56	
41	1	VR2	500K	500K 6mm Single Turn Cermet Pot	Panasonic	EVM-36GA00B55	36G55-ND	\$ 0.56	
42	1	Y1	3.579MHz	3.579545MHz Color Burst Crystal	CTS	ATS036	CTX400-ND	\$ 1.31	

- NOTES:**
- 1.) BOM shown is for version with optional de-emphasis circuit installed. Remove C3 and change R3 & R4 to 100K to disable de-emphasis.
 - 2.) PCB1, U1 and U3 are items included with partial kit.
 - 3.) Item 9 - D2 (1N5240B) is not installed.
 - 4.) Digi-Key pricing based on Catalog T012. Pricing may vary.

NHRC LLC Limited Warranty

NHRC LLC warrants that it's assembled and tested products will be free from defects in materials and workmanship for a period of NINETY DAYS from the date of shipment. During this period, NHRC LLC will repair or replace, at our option, any of our products that fail as a result of defects in materials or workmanship. NHRC LLC's liability will be limited to parts, labor, and return shipping for this period.

NHRC LLC warrants that it's kit products will contain components that are free from defects in materials and workmanship for a period of THIRTY DAYS from the date of shipment. During this period, NHRC will replace any of the components in a kit ONCE. Subsequent replacement of any component any subsequent times is completely at the discretion of NHRC LLC, and may require the complete return of the kit.

In no case will NHRC LLC be liable for products damaged by improper wiring (including, but not limited to, over-voltage or application of reverse polarity), physical damage resulting from misuse and/or abuse of the product, neglect, or acts of God (lightning, floods, etc.).

Unauthorized modification of a NHRC product will void the warranty on the modified product.

In no case will NHRC LLC be liable for any direct, consequential, or incidental loss or damage resulting from the use or inability to use any of it's products.

Some states or countries do not allow the limitation of incidental or consequential damages, so the paragraph above may not apply to you.

This warranty applies only to the original purchaser of the product; proof of purchase must be presented to receive warranty service.